

Low Voltage Battery

# Quick Installation Guide

---



LB-5D-G2

## 1 General Declaration

- Read this quick installation guide carefully before installation to learn about product features and safety precautions.
- Only qualified personnel are allowed to install, operate, and maintain the equipment.
- Installers should be familiar with local laws and regulations.
- Check the deliverables for correct model, complete contents, and intact appearance. Contact the manufacturer if any damage is found or any component is missing.
- Installers must use insulated tools and wear personal protective equipment.
- As required by local regulations, an overcurrent protection and isolation device should be installed between the inverter and the battery. The cable needs to be prepared by the installer.
- Before installation, ensure that the battery is turned off, and any associated circuit breakers and disconnect switches are turned off.
- The information in this quick installation guide is subject to change due to product updates or other reasons.

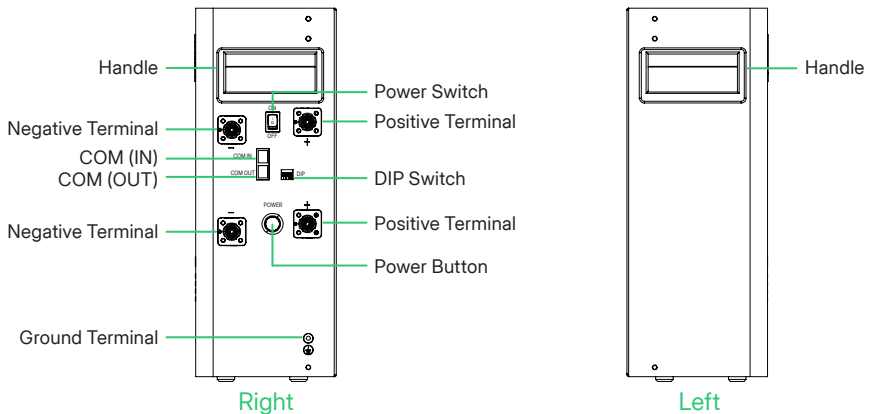
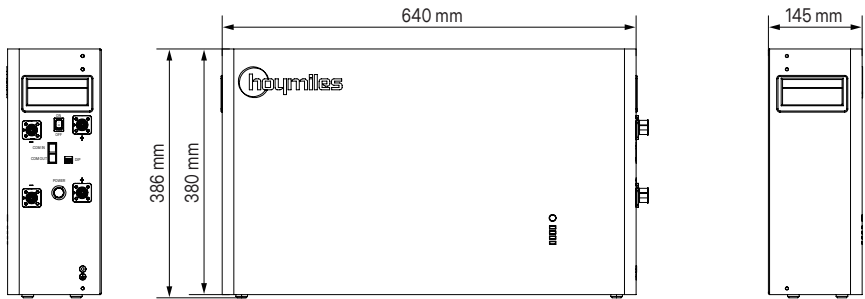







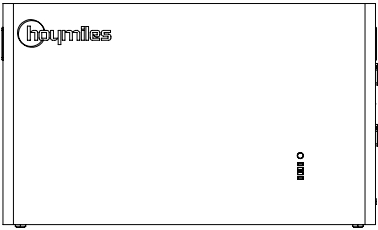

## 2 Product Overview

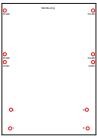

| Pin Definition  | Terminal | 1          | 2          | 3         | 4     | 5     | 6         | 7  | 8    |
|---|----------|------------|------------|-----------|-------|-------|-----------|----|------|
|  | COM IN   | 485-1A-PCS | 485-1B-PCS | 485-2A-IN | CAN1H | CAN1L | 485-2B-IN | DI | GND1 |
|  | COM OUT  | NC         | NC         | 485-2A-IN | NC    | NC    | 485-2B-IN | DO | GND2 |

\* If you want to use a communication cable prepared by yourself, the PIN of the cable end connected to the inverter should only reserve 4 (CAN1H) and 5 (CAN1L).

### 3 Packing List

|  |   |   |
|--|---|---|
| <br>Battery*1   | <br>Bracket L*1<br>Bracket R*1 | <br>Bracket A*2                  |
| <br>Communication Cable*2                             | <br>Ground Cable*1           | <br>Levelling Feet*4             |
| <br>Screw M5*14*7                                     | <br>Positioning cardboard*1  | <br>Power Cable*2                |
| <br>Battery Connector (+)*1<br>Battery Connector (-)*1 | <br>Expansion Screw M8*80*6  | <br>Quick Installation Guide*1 |
|  |   | <br>Certificate*1              |

## 4 Installation Instruction

### Environmental Requirements

- The recommended ambient temperature is between 15°C and 35°C.
- The recommended relative humidity is between 10% and 95%, without condensing.
- The altitude should be no more than 2000 m.
- The product should be installed in an environment with good ventilation and heat dissipation conditions.
- The product should be installed indoors and should meet the following requirements, including but not limited to:
  - a) Keep distance from doors, windows, or other batteries.
  - b) Keep away from the heating device.
  - c) Keep away from corrosive chemicals.

### Space Requirements

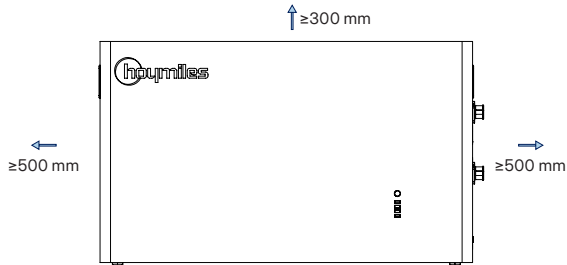

### Installation Tools

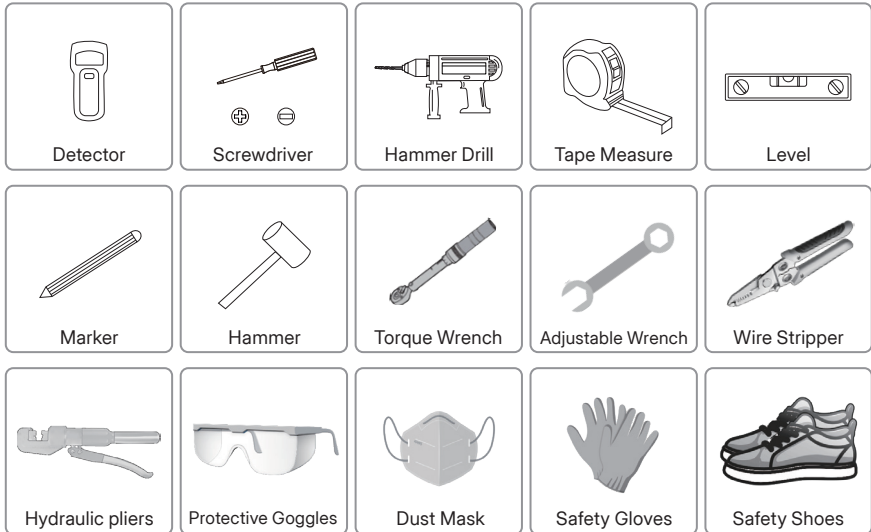

## Installation Steps

### Wall Mounting

#### Step 1 Marking the Hole Position

1. Select a load bearing wall constructed with reinforced concrete and use a detector to detect whether there are cables or water tubes behind it.
2. Place the positioning paper (Wall Mounting Side) against the wall and mark the hole position. (Mark the hole position according to actual installation.)

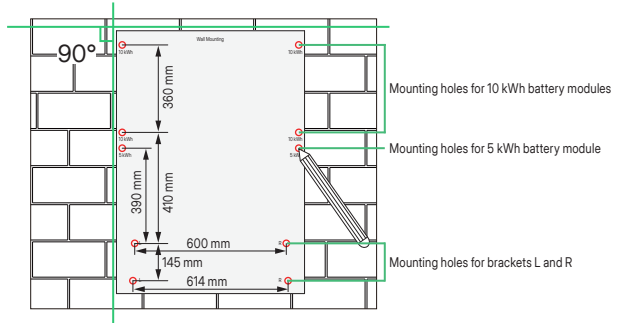

#### Step 2 Drilling Holes

Use a hammer drill to drill holes with a diameter of 12 mm and a depth of 65 mm.

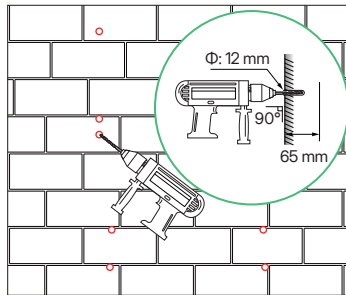

#### Step 3 Installing Bracket L and Bracket R

1. Hammer the M8 expansion screws into the hole according to the quantities you need and unscrew the screws.

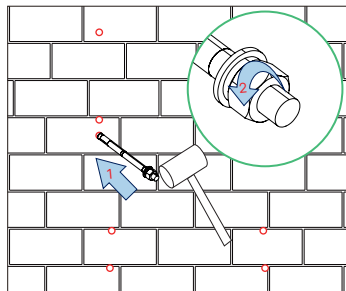

2. Place the bracket L according to the bottom 4 holes.
3. Use M8 expansion screws to fix the bracket L on the wall with a torque of 15 N·m.
4. The method to install bracket R is the same as that of bracket L.

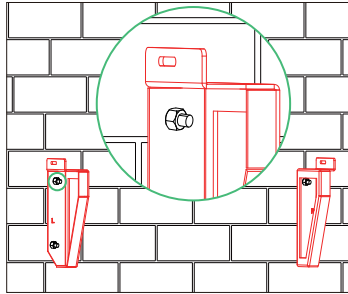

⊕ M8 ⌚ 15 N·m

#### Step 4 Placing the Battery

1. Hold the handles to lift the battery and place it on the bracket L and bracket R.
2. Use M5 screws to fix the battery to the bracket L and bracket R with a torque of 5 N·m.

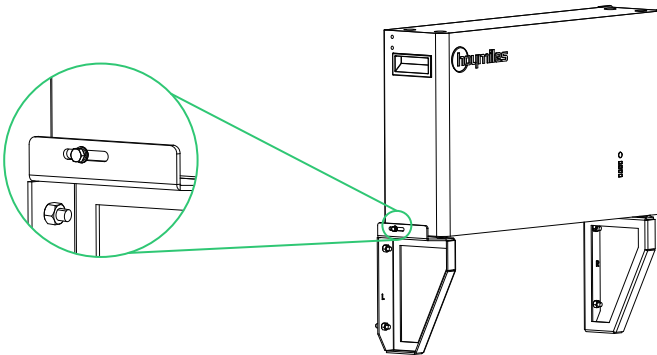

⊕ M5 ⌚ 5 N·m

#### Step 5 Stacking Batteries (Optional)

1. Remove the 4 Nylon hole plugs on the top of the battery A.

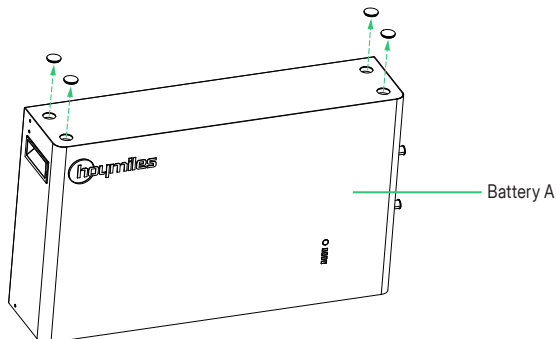

2. Hold the handles to lift the battery B and place it on the battery A aiming at 4 limit holes.
  3. Use bracket A and M5 screws to secure the connection between battery A and battery B.
  4. Use M8 expansion screws to fix the bracket A on the wall.
  5. Use bracket A, M5 screws, and M8 expansion screws to secure the battery B. (The method is the same as described previously.)
- \* Up to 2 batteries can be stacked.

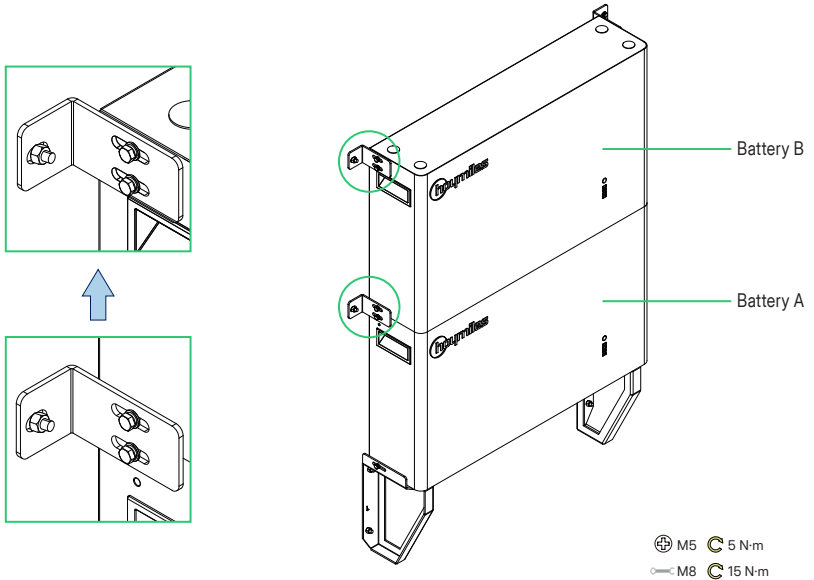

### Step 6 Completing the installation

1. Use M5 screws to fix the bracket A on the top left and top right of the battery.
2. Use M8 expansion screws to fix the bracket A on the wall.

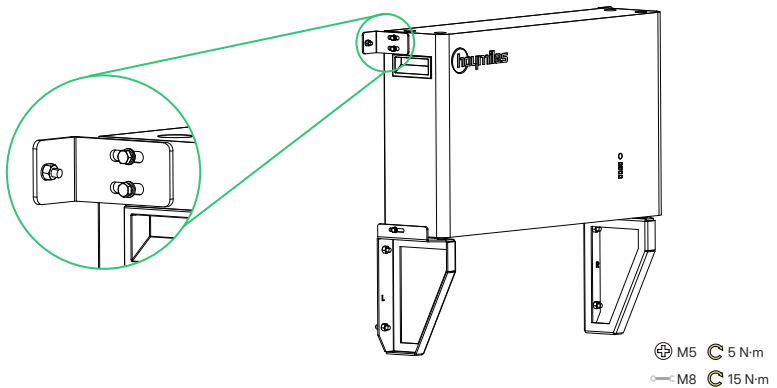

## Floor Standing

### Step 1 Drilling Holes

As described in the wall mounting steps, according to the actual installation, place the positioning paper (Floor Standing Side) against the wall, mark hole position (for bracket A), drill holes, and hammer the sleeves into the holes.

### Step 2 Installing Levelling Feet

1. Place a soft cloth on the ground, hold the handles to slowly lift the battery, and lay it on the soft cloth.
2. Install the 4 levelling feet and tighten them.

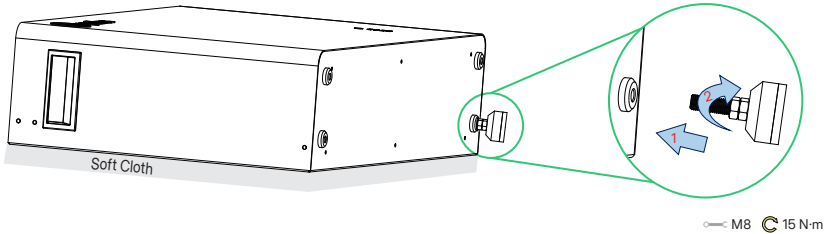

### Step 3 Placing the Battery

Place the battery on a level ground ( $0^{\circ}$ - $3^{\circ}$ ), parallel to the wall, and keep a distance of at least 20 mm.

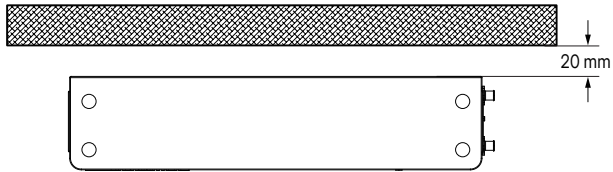

### Step 4 Stacking Batteries (Optional)

1. Remove the 4 Nylon hole plugs on the top of the battery A.

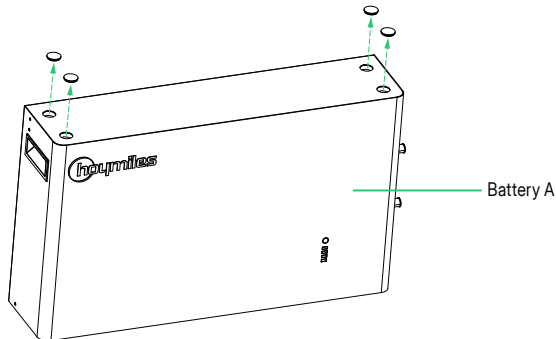

2. Hold the handles to lift the battery B and place it on the battery A aiming at 4 limit holes.
3. Use bracket A and M5 screws to secure the connection between battery A and battery B.
4. Use M8 expansion screws to fix the bracket A on the wall.
5. Use bracket A, M5 screws, and M8 expansion screws to secure the battery B. (The method is the same as described previously.)

\* Up to 4 batteries can be stacked.

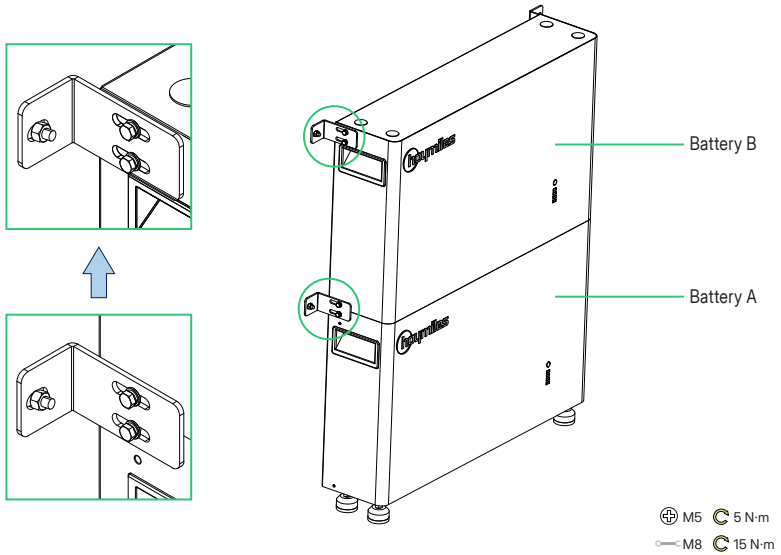

### Step 5 Completing the Installation

1. Use M5 screws to fix the bracket A on the top left and top right of the battery.
2. Use M8 expansion screws to fix the bracket A on the wall.

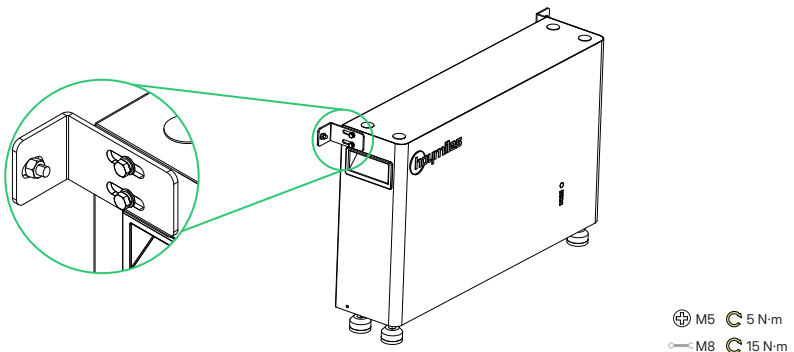

## 5 Electrical Connection

### NOTICE

- Before the electrical connection, ensure that all power supplies are disconnected.
- It is recommended that a circuit breaker between the inverter and the battery be installed in accordance with local laws and regulations.

| Cable               | Specification             |
|---------------------|---------------------------|
| Ground Cable        | 16 mm <sup>2</sup> /6 AWG |
| Positive Cable      | 25 mm <sup>2</sup> /4 AWG |
| Negative Cable      | 25 mm <sup>2</sup> /4 AWG |
| Communication Cable | Standard Ethernet cable   |

\* The communication cables are available in two lengths. The 1 m cable (marked by BAT) is for parallel connection, and the 1.5 m (marked by INV) cable is used to connect to the inverter.

### Single-battery System

The maximum charging or discharging current of the battery is 50 A. If the current exceeds 50 A, it may cause a risk of fire accident.

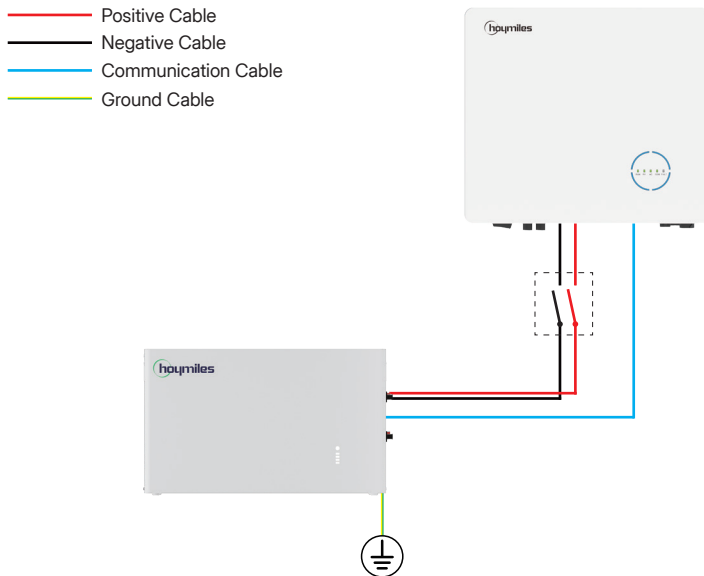

## Multi-battery System

### Parallel Connection without Busbar (Number of Batteries=2)

- When two batteries are connected in parallel, they can be connected without a busbar, and the maximum charging or discharging current of the battery system is 100 A. If the current exceeds 100 A, it may cause a risk of fire accident.
- For wall mounting batteries, this system supports up to 2 batteries being stacked in one battery tower.
- For floor standing batteries, this system supports up to 4 batteries being stacked in one battery tower.
- The stackable quantities of every battery tower must be the same.
- If the first parallel operation fails, it may be caused by inconsistent SOC among batteries. Please check the voltage of each battery. If the voltage difference exceeds 0.5 V, set the battery with the lowest voltage as the Master, and enable the force charging mode to charge the battery at a maximum power of 10% until the parallel operation is successful.

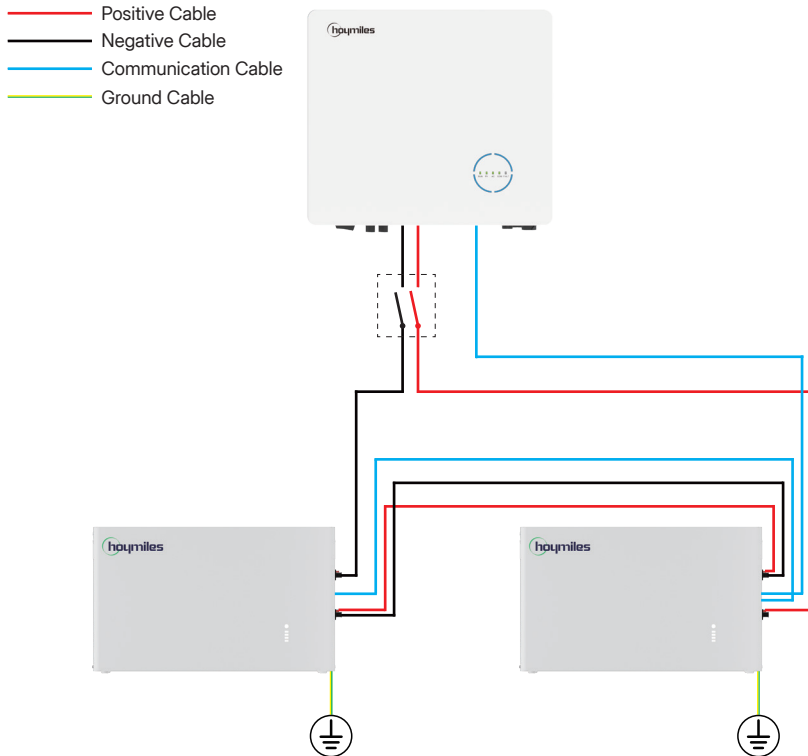

**Parallel Connection with Busbar (Number of Batteries≥3)**

- LB-5D-G2 series supports up to 16 batteries in parallel.
- When three or more batteries are connected in parallel, they must be connected through a busbar.
- For wall mounting batteries, this system supports up to 2 batteries being stacked in one battery tower.
- For floor standing batteries, this system supports up to 4 batteries being stacked in one battery tower.
- The stackable quantities of every battery tower must be the same.
- If the first parallel operation fails, it may be caused by inconsistent SOC among batteries. Please check the voltage of each battery. If the voltage difference exceeds 0.5 V, set the battery with the lowest voltage as the Master, and enable the force charging mode to charge the battery at a maximum power of 10% until the parallel operation is successful.

- Positive Cable
- Negative Cable
- Communication Cable
- Ground Cable
- - - Parallel Cable for Inverters

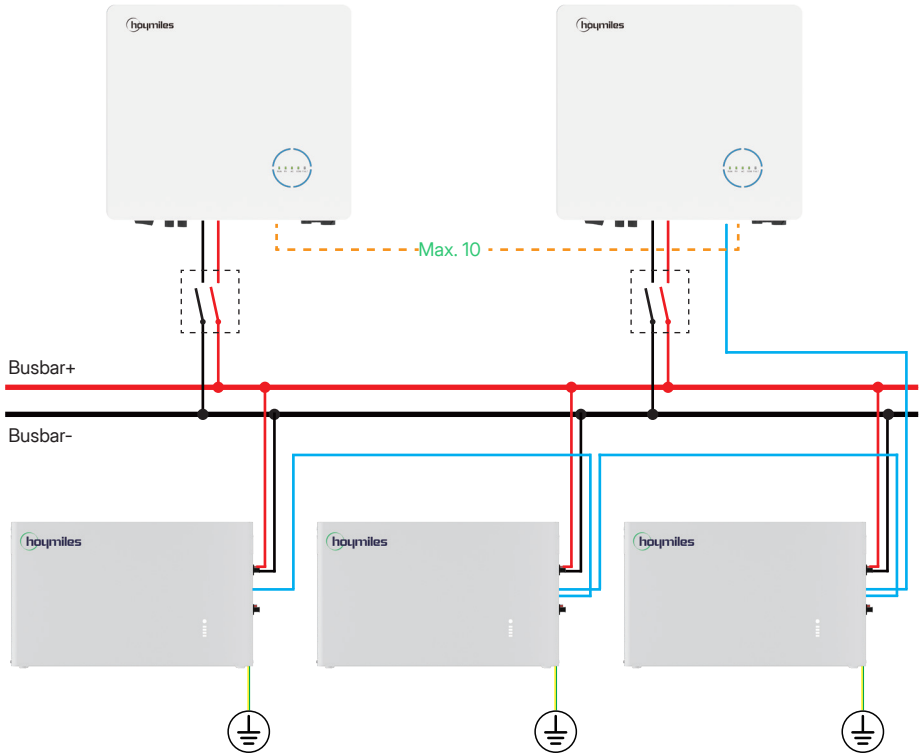

### Single-battery System

**Step 1** Connect the ground cable.

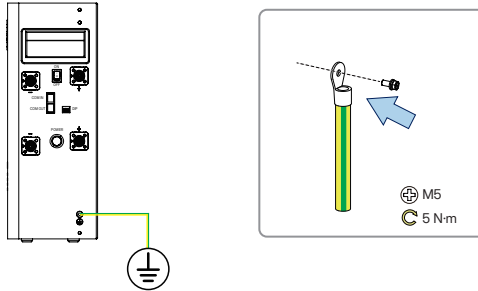

**Step 2** Connect one end (quick connectors) of power cables to the battery terminals, and connect the other end to the inverter. If needed, the cable ends connected to the inverter should be assembled using battery connectors provided by the inverter manufacturer.

**Step 3** Connect the communication cable.

### Multi-battery System

**Step 1** Connect ground cable. The connection method is the same as that described above.

**Step 2** Connect power cables as shown in the following figures.

**Parallel Connection without Busbar (Number of Batteries=2)**

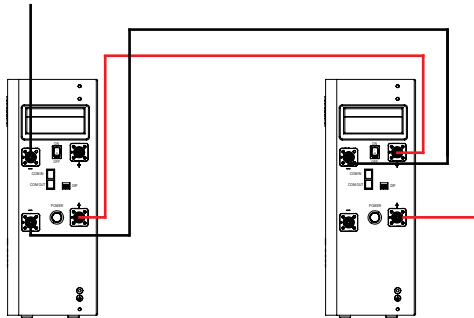

**Note:**

- If needed, the cable ends connected to the inverter should be assembled using battery connectors provided by the inverter manufacturer.
- The method of assembling the battery connectors and power cables for parallel connection is shown as follows.

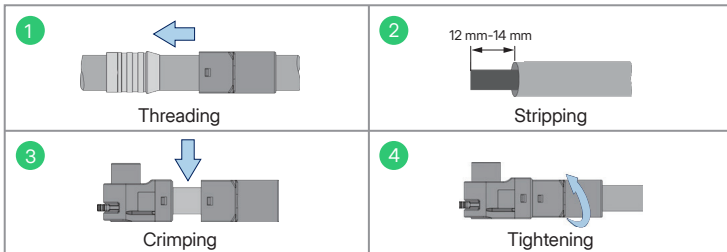

### Parallel Connection with busbar (Number of Batteries $\geq$ 3)

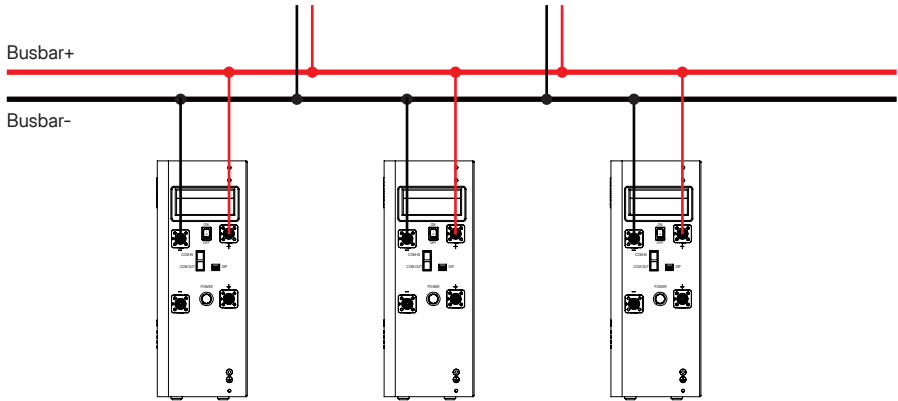

**Step 3** Connect communication cables.

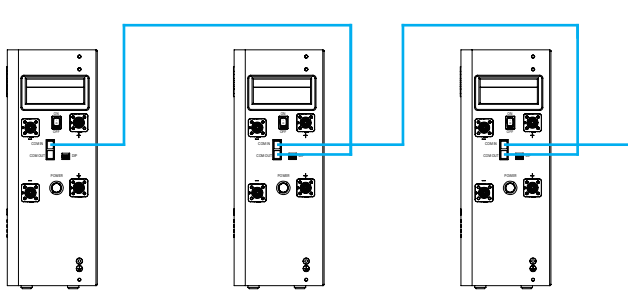

## 6 System Power-on

**Step 1** Turn on the circuit breaker between the battery and the inverter.

**Step 2** Turn on the power switch. The battery will be in self-check state and all indicators will flash blue (0.5s gap).

**Step 3** (Optional) When the inverter is powered only by the battery, press the "POWER" button on the Master battery for 1s.

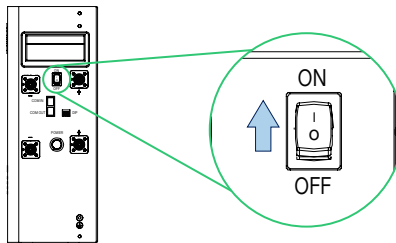

### Note 1: DIP Switch

- If the battery works with Hoymiles inverters, leave the DIP Switch as default.
- If the battery works with non-Hoymiles inverters, please contact Hoymiles.

**Note 2: (If Needed) System Power-off**

- Step 1 Turn off the circuit breaker between the battery and the inverter.
- Step 2 Press the "POWER" button on the Master battery for 3s.
- Step 3 Turn off the power switch.

**LED Indicators**

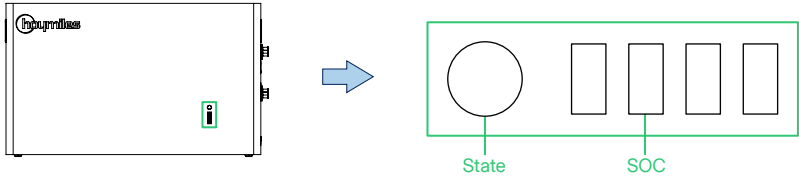

| Indicator | Indicator Status          | Battery Status  |
|-----------|---------------------------|---|
|           | Solid blue.               | The battery works normally or is in standby.  |
|           | Solid red.                | A fault occurs.   |
|           | 1/4 LED on.               | SOC is 0-25%.   |
|           | 2/4 LEDs on.              | SOC is 25%-50%.   |
|           | 3/4 LEDs on.              | SOC is 50%-75%.   |
|           | All LEDs on.              | SOC is 75%-100%.  |
|           | Flashing blue (0.5s gap). | The battery is in precharge;<br>The battery is in self-check;<br>The battery is being upgraded. |
|           | Flashing (0.5s gap).      | Communication failure.  |
|           | The indicators are off.   | The battery is turned off.  |

**7 EU Declaration of Conformity**

Hoymiles Power Electronics Inc. hereby declares that Hoymiles Battery (model: LB-5D-G2) is in compliance with the essential requirements and other relevant provisions of directives 2014/30/EU, 2011/65/EU, (EU)2015/863, and EU Battery Regulation (EU)2023/1542.

The original EU Declaration of Conformity may be found at <https://www.hoymiles.com>.





User Manual in the QR code or at  
[www.hoymiles.com/resources/download/](http://www.hoymiles.com/resources/download/)



Installation video in the QR code or at  
[www.youtube.com/@Hoymiles/videos](http://www.youtube.com/@Hoymiles/videos)



**Hoymiles Power Electronics Inc.**

Add: Floor 6-10, Building 5, 99 Housheng Road, Gongshu District,  
Hangzhou 310015, P. R. China

Tel: +86 571 2805 6101

Email: [service@hoymiles.com](mailto:service@hoymiles.com)

[support@hoymiles.com](mailto:support@hoymiles.com)

[www.hoymiles.com](http://www.hoymiles.com)



AP041018